

# Largo LAX 614 Specifications

- **1 x 90mm Waste with Basket Strainer Waste.** Capable of adaptation to take Waste Disposal Unit
- **Dedicated Basket Waste in recessed drainer**
- **Large practical Largo main bowl**
- **Creates complete wet area**
- **Dedicated accessories**
- **Chopping Board slides along total length**

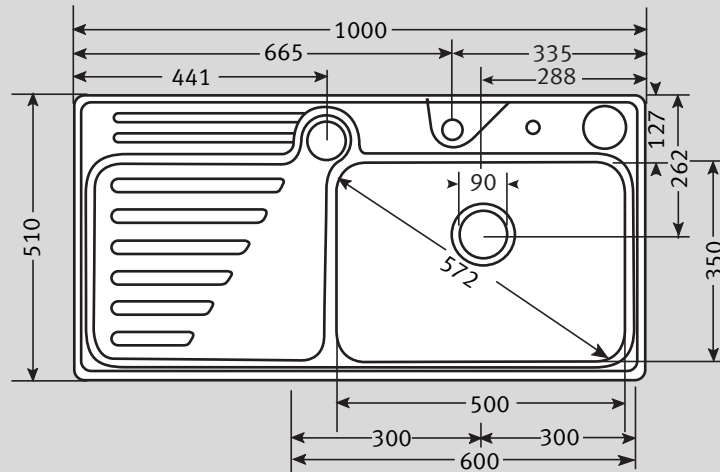

<b>Material:</b>	Stainless Steel
<b>Application:</b>	Inset
<b>Bowl size:</b>	500 x 350 x 180 (welded to frame)
<b>Drainer Format:</b>	Left or Right hand drainer available
<b>Cut-out size:</b>	984 x 494 (cr = 20)
<b>Colour:</b>	Silk Stainless Steel
<b>Seal:</b>	Factory fitted polyurethane seal
<b>Insulation:</b>	Grey Dynaphon for heat and sound
<b>Heat Resistance:</b>	Up to 300°C
<b>Earthing Point:</b>	Supplied with sink

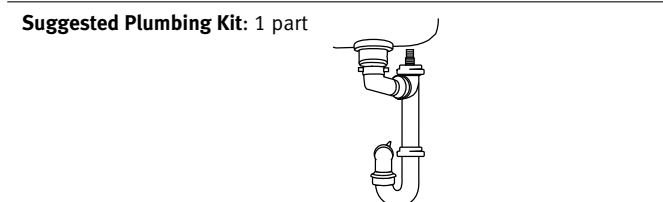
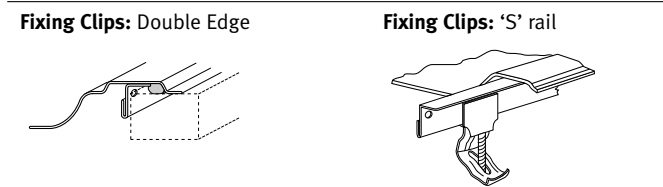
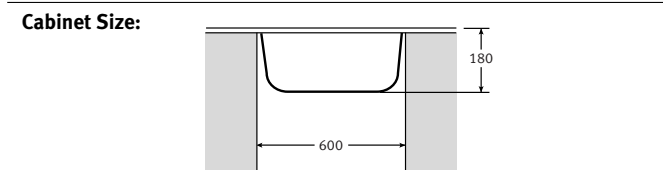

**Waste:** 1 x Lira 90mm Basket Strainer Waste with overflow & Pop-up assembly

**Overflow:**

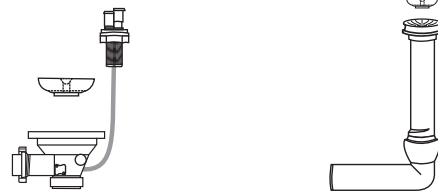

**Accessories available:**

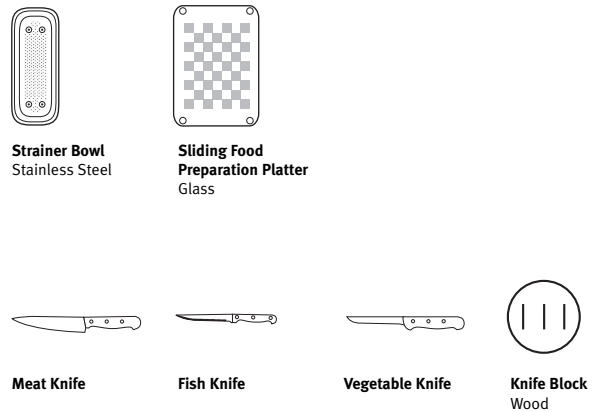

**Taps:** Any Franke tap can be utilised with this model\*.

\*Ceramic disc taps in certain installations or where there is a low head of water (below 4 metres) may not provide adequate flow rates. You are advised to check with your supplier.

**Guarantee:** Franke sinks are guaranteed for 25 years against manufacturing defect. Franke taps are guaranteed against defective materials and workmanship for 1 year in relation to coatings and finishes, and 5 years in relation to moving parts. Franke will replace (and where appropriate repair) defective sinks. In relation to taps, Franke will where appropriate provide replacement parts for your taps or replace your taps. Any associated or ancillary costs to be incurred by you as a result of replacement of Franke sinks and taps under this guarantee shall in all cases be previously approved by Franke UK Limited.

This guarantee is in addition to and does not affect your statutory rights.